

# Ultraview Pro™

PROFESSIONAL KVM SWITCH WITH ON-SCREEN DISPLAY

## INSTALLATION AND OPERATIONS MANUAL



10707 Stancliff Road  
Phone: (281) 933-7673

Houston, Texas 77099  
Internet: [WWW.ROSE.COM](http://WWW.ROSE.COM)



## LIMITED WARRANTY

Rose Electronics warrants the UltraView Pro™ to be in good working order for one year from the date of purchase from Rose Electronics or an authorized dealer. Should this product fail to be in good working order at any time during this one-year warranty period, Rose Electronics will, at its option, repair or replace the Unit as set forth below. Repair parts and replacement units will be either reconditioned or new. All replaced parts become the property of Rose Electronics. This limited warranty is valid only if repairs are performed by Rose Electronics or a Rose qualified service technician. This limited warranty is void if repairs are not performed by Rose Electronics or a Rose qualified service technician. This limited warranty does not include service to repair damage to the Unit resulting from accident, disaster, abuse, or unauthorized modification of the Unit, including static discharge and power surges.

Limited Warranty service may be obtained by delivering this unit during the one-year warranty period to Rose Electronics or an authorized repair center providing a proof of purchase date. If this Unit is delivered by mail, you agree to insure the Unit or assume the risk of loss or damage in transit, to prepay shipping charges to the warranty service location, and to use the original shipping container or its equivalent. You must call for a return authorization number first. Under no circumstances will a unit be accepted without a return authorization number. Contact an authorized repair center or Rose Electronics for further information.

ALL EXPRESS AND IMPLIED WARRANTIES FOR THIS PRODUCT INCLUDING THE WARRANTIES OF MERCHANTABILITY AND FITNESS FOR A PARTICULAR PURPOSE, ARE LIMITED IN DURATION TO A PERIOD OF ONE YEAR FROM THE DATE OF PURCHASE, AND NO WARRANTIES, WHETHER EXPRESS OR IMPLIED, WILL APPLY AFTER THIS PERIOD. SOME STATES DO NOT ALLOW LIMITATIONS ON HOW LONG AN IMPLIED WARRANTY LASTS, SO THE ABOVE LIMITATION MAY NOT APPLY TO YOU.

IF THIS PRODUCT IS NOT IN GOOD WORKING ORDER AS WARRANTIED ABOVE, YOUR SOLE REMEDY SHALL BE REPLACEMENT OR REPAIR AS PROVIDED ABOVE. IN NO EVENT WILL ROSE ELECTRONICS BE LIABLE TO YOU FOR ANY DAMAGES INCLUDING ANY LOST PROFITS, LOST SAVINGS OR OTHER INCIDENTAL OR CONSEQUENTIAL DAMAGES ARISING OUT OF THE USE OF OR THE INABILITY TO USE SUCH PRODUCT, EVEN IF ROSE ELECTRONICS OR AN AUTHORIZED DEALER HAS BEEN ADVISED OF THE POSSIBILITY OF SUCH DAMAGES, OR FOR ANY CLAIM BY ANY OTHER PARTY.

SOME STATES DO NOT ALLOW THE EXCLUSION OR LIMITATION OF INCIDENTAL OR CONSEQUENTIAL DAMAGES FOR CONSUMER PRODUCTS, SO THE ABOVE MAY NOT APPLY TO YOU. THIS WARRANTY GIVES YOU SPECIFIC LEGAL RIGHTS AND YOU MAY ALSO HAVE OTHER RIGHTS WHICH MAY VARY FROM STATE TO STATE.

NOTE: This equipment has been tested and found to comply with the limits for a Class A digital device, pursuant to Part 15 of the FCC Rules. These limits are designed to provide reasonable protection against harmful interference when the equipment is operated in a commercial environment. This equipment generates, uses, and can radiate radio frequency energy and, if not installed and used in accordance with the instruction manual, may cause harmful interference to radio communications. Operation of this equipment in a residential area is likely to cause harmful interference in which case the user will be required to correct the interference at his own expense.

IBM®, AT, and PS/2 are trademarks of International Business Machines Corp.  
Microsoft® and Microsoft Windows™ are registered trademarks of Microsoft Corp.  
Apple, Macintosh, and ADB are trademarks of Apple Computer, Inc.  
Sun is a registered trademark of Sun Microsystems Inc.  
Any other trademarks mentioned in this manual are acknowledged to be the property of the trademark owner.

Copyright © Rose Electronics 1990-2002. All rights reserved.  
No part of this manual may be reproduced, stored in a retrieval system, or transcribed in any form or any means, electronic or mechanical, including photocopying and recording, without the prior written permission of Rose Electronics.

Rose Electronics Part # MAN-UVP15  
Printed In the United States of America ■ Revision 1.5

## **FCC/IC STATEMENTS, EU DECLARATION OF CONFORMITY**

### **FEDERAL COMMUNICATIONS COMMISSION AND INDUSTRY CANADA RADIO-FREQUENCY INTERFERENCE STATEMENTS**

This equipment generates, uses, and can radiate radio frequency energy and if not installed and used properly, that is, in strict accordance with the manufacturer's instructions, may cause interference to radio communication. It has been tested and found to comply with the limits for a Class B digital device in accordance with the specifications of Part 15 of FCC rules, which are designed to provide reasonable protection against such interference when the equipment is operated in a commercial environment. Operation of this equipment in a residential area is likely to cause interference, in which case the user at his own expense will be required to take whatever measures may be necessary to correct the interference.

Changes or modifications not expressly approved by the party responsible for compliance could void the user's authority to operate the equipment. This digital apparatus does not exceed the Class A limits for radio noise regulation of industry Canada.

Le présent appareil numérique n'émet pas de bruits radioélectriques dépassant les limites applicables aux appareils numériques de la classe A prescrites dans le Règlement sur le brouillage radioélectrique publié par Industrie Canada.

### **EUROPEAN UNION DECLARATION OF CONFORMITY ACCORDING TO COUNCIL DIRECTIVE 89/336EEC**

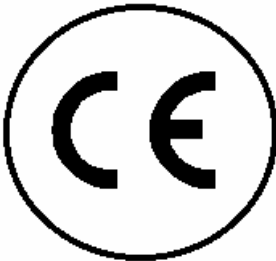

This equipment is in conformity with the requirements of the European EMC directive 89/336/EEC in respect of:  
EN55022: (Class B)  
EN50082-1 / EN60555-2, and  
The Low Voltage Directive.

# TABLE OF CONTENTS

## Contents

Disclaimer .....	1
Introduction / System overview .....	1
Features .....	2
Package contents .....	2
Compatibility .....	3
Rose Electronics web site .....	3
System overview .....	3
KVM station .....	3
CPU connection .....	4
Cascading Units .....	4
Menu system .....	4
UltraView Pro models .....	5
UltraView Pro models (rear) .....	6
UltraView Pro Cables .....	7
UltraView Pro to KVM station cable .....	7
UltraView Pro to CPU cables .....	7
UltraView Pro master to slave cables .....	7
Organizing the system .....	8
Installation – single unit .....	8
Step 1. Connecting the keyboard, video monitor, and mouse .....	8
Step 2. Apply power to UltraView Pro .....	8
Step 3. Connecting the computers .....	9
Installation - Cascading units .....	10
Slave unit installation .....	11
Main configuration menu .....	13
Configure system menu .....	14
Configure computer menu .....	18
Configure overlay .....	20
Configure security .....	24
Selecting a computer .....	26
Keyboard commands .....	27
Keyboard command usage .....	29
Reset to factory defaults .....	29
Rackmounting .....	29
Serial Port (RS232) .....	30
Firmware update .....	30
TROUBLESHOOTING .....	33
Service Information .....	35
Maintenance and Repair .....	35
Technical Support .....	35
Safety .....	36
Safety and EMC Regulatory Statements .....	37

## Figures

Figure 1. UltraView models .....	5
Figure 2. Rear Panel .....	6
Figure 3. UltraView Pro to CPUs .....	10
Figure 4. Cascading units.....	11
Figure 5. Main configuration menu .....	13
Figure 6. Configure system menu.....	14
Figure 7. Configure computer menu .....	18
Figure 8. Configure overlay menu.....	20
Figure 9. Configure security .....	24
Figure 10. Computer select window.....	26
Figure 11. Power-on diagnostic screen.....	32

## Tables

Table 1. Front panel .....	5
Table 2. Rear panel connectors.....	6
Table 3. Typematic rate.....	16
Table 4. Keyboard commands.....	27
Table 5. Mode command values.....	28
Table 6. Resolution command values.....	28

## Appendices

Appendix A. Initial factory settings .....	39
Appendix B. Parts and cables .....	40
Appendix C. General Specifications .....	41
Appendix D. Rack mount instructions .....	42
Appendix E. Rack mount illustration .....	43
Appendix F. Keyboard mapping .....	43
Appendix G. Video distance capability.....	44

# INTRODUCTION

## Disclaimer

While every precaution has been taken in the preparation of this manual, the manufacturer assumes no responsibility for errors or omissions. Neither does the manufacturer assume any liability for damages resulting from the use of the information contained herein. The manufacturer reserves the right to change the specifications, functions, or circuitry of the product without notice.

The manufacturer cannot accept liability for damages due to misuse of the product or other circumstances outside the manufacturer's control. The manufacturer will not be responsible for any loss, damage, or injury arising directly or indirectly from the use of this product.

## Introduction / System overview

Thank you for choosing the Rose Electronics UltraView Pro™ Professional KVM switch. The UltraView Pro represents the latest technology in keyboard-video monitor-mouse switching. It features an on-screen display for easy configuration and computer switching. The UltraView Pro is the result of Rose Electronics commitment to providing state-of-the-art switching solutions for today's demanding work place. The UltraView Pro has proven to be a valuable and dependable investment for users that have the need to access multiple computer systems from a single KVM station.

A **K**eyboard, **V**ideo monitor and **M**ouse are referred to throughout this manual as a **KVM** station.

Please refer to the safety section first before proceeding with any installation or configuration of the UltraView Pro.

The UltraView Pro is available in three models.  
The "M" chassis – 2 or 4 computer ports  
The "B" chassis – 4 or 8 computer ports  
The "C" chassis – 4, 8, 12, or 16 computer ports

Each model can support either PC/Unix or multi-platform (PC, Apple, Sun, USB, and Unix workstations) systems. All models feature an advanced on-screen display for easy configuration of the UltraView Pro. Switching to a connected computer can be done by simple keyboard commands, an on-screen list of the computers or by selecting the computer from the front panel.

All UltraView Pro models can easily be expanded by chaining the units together and configuring the system using the on-screen configuration menus. Using 4 port units (“M” chassis), you can expand the UltraView Pro to 16 computers. Using 16 port units (“C” chassis) you can expand to 256 computers.

## Features

---

- Access up to 256 computers from one KVM station.
- Supports PC or Multi-platform systems.
- On-screen display for easy configuration and CPU switching.
- The connected computers name is displayed on-screen with adjustable font, color, and screen position.
- Choose computer from an on-screen list, keyboard command or from the front panel.
- Supports all PC, Macintosh, and Sun video types.
- Supports video resolutions up to 1600x 1280 (non-interlaced video).
- Programmable keyboard typematic rate and delay for PCs.
- PS/2, Serial, Apple ADB, and Sun mouse types supported.
- PC, PS/2, AT, Apple, Sun, Unix and USB keyboards supported.
- Compatible with PC, Apple, Sun, and Unix workstations.
- Unix workstations supported include IBM RS/6000, SGI, HP, DEC, and other workstations that use a PC style keyboard.
- Front panel LEDs show selected computer and power on state.
- Scan function sequences through the connected computers at rates of 1 to 999 seconds.
- Microprocessor controlled keyboard and mouse emulation.
- Keyboard and mouse modes, Num Lock, Caps Lock, and Scroll Lock settings are saved for each connected computer.
- Four different screen savers are available.
- Flash memory saves all configurations and settings. Firmware updates are available on Rose Electronics web site.
- Available in 2, 4, 8, 12, or 16 port models.
- Rack mount kits are available for 19”, 23”, and 24” racks.

## Package contents

---

The package contents consists of the following:

- The UltraView Pro unit.
- Power adapter (provided with M-chassis).
- Installation and operations manual.

CPU, KVM, and expansion cables are usually ordered separately. If the package contents are not correct, contact Rose Electronics or your reseller so the problem can be quickly resolved.

## Compatibility

Computers	Industry standard PCs, Sun, Unix computers such as RS/6000, HP, SGI, DEC, and others.
Monitors	VGA, SVGA, XGA, RGB, Composite
Keyboards	PC/Unix US, most foreign Qwerty keyboards, Korean and Japanese, keyboards with or without Windows keys (101, 102, 104, 105, 106, 109 keys), USB*, Sun**, Apple ADB**. Some older XT/AT auto-sensing keyboards may not be compatible.
Mouse	Standard PS/2, PS/2 wheel, Serial 2 or 3 button* USB* SUN** Apple ADB**
Audio Devices**	Audio speakers Microphone
Serial Devices**	Touchscreen Graphics tablet

\* Available for CPU ports only

\*\* Available on multi-platform models only

## Rose Electronics web site

Visit our web site at [www.rose.com](http://www.rose.com) for additional information on the UltraView Pro and other products offered by Rose Electronics that are designed for data center applications, classroom environments and many other switching applications.

## System overview

The UltraView Pro is designed to provide seamless, trouble-free switching from a single KVM station to any connected CPU. You can switch to any of the connected computers by simple keyboard commands, the front panel + or - buttons, or an on-screen list of computers. If your system demands are greater than a single unit can provide, the UltraView Pro can be easily expanded to connect up to 256 computers.

## KVM station

A KVM station, consisting of a keyboard, video monitor and mouse, connects to the UltraView Pro's DB25F connector that is labeled monitor/keyboard/mouse. The keyboard, video monitor and mouse used for the KVM station should be compatible with all of the CPUs that will be connected.

## CPU connection

---

All CPU connectors on the UltraView Pro are DB25F. The CPUs are connected to the UltraView Pro using a CPU cable designed to interface with the CPU type such as a PC, SUN or Apple. A CPU cable is needed for each connected Computer.

## Cascading Units

---

The UltraView Pro is designed to allow for expanding from a single unit to multiple units. When set up in this configuration, one unit is designated as the master unit and the other UltraView Pro units are designated as slave units. Each CPU connector on the master unit can be connected to the KVM connector on a slave unit. Using a 16 port UltraView Pro as the master and 16 port units for the 16 slaves, expands the capability to 256 computers. A switch-to-switch cable for each slave unit is needed.

## Menu system

---

The UltraView Pro's menu system makes it very easy to configure the system (KVM station and unit), the connected computers, the colors, resolution, screen saver, and the general appearance of the on-screen displays and labels.

To access the UltraView Pro's menu system, first press and release the left control <Ctrl> key. Then, within 2 seconds, press the F12 key. The main configuration menu will display.

To navigate through the configuration menus, use the up/down arrow keys to select the section needing configuration. Once the section is selected (highlighted), pressing enter will either display that sections configuration menu, display an input box to enter new values, or show a list of available choices.

To exit the menu system select Exit from the main configuration menu and press enter. If any changes have been made you will be prompted to either save the changes or exit without saving the new configurations. If you choose yes, the changes are saved to flash memory. If you choose no, the changes will stay in effect as long as the unit has power. Once power is removed from the unit, unless saved, all changes are discarded.

Each item in the menu system is explained in detail in the menu section of this manual.

# MODELS

## UltraView Pro models



Figure 1. UltraView models





Label		Description
Power		Power LED (Green when unit is on)
On/Off		"M" chassis only. In = ON Out = OFF
LEDs		Indicator LEDs; Numbered pairs of LEDs shows status and power of connected computers.
+ And – switches*		+ Connects to the next sequential CPU, - Connects to the previous sequential CPU.

Table 1. Front panel

\* The + and – switches are also used when upgrading the firmware, to reset the unit to factory default, and diagnostics.

## UltraView Pro models (rear)

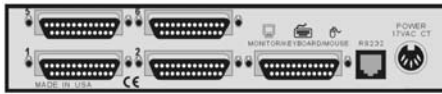

“M”  
Chassis



“B”  
Chassis



“C”  
Chassis

Figure 2. Rear Panel





Label	Connector	Description
Power		“M” Chassis only DIN 5F – Power adapter connector.
None		“B” and “C” Chassis IEC320 power receptacle w/on-off switch.
1 – 4 (“M” chassis) 1 – 8 (“B” chassis) 1 – 16 (“C” chassis)		DB25F – CPU adapter cable connectors.
MONITOR/ KEYBOARD/ MOUSE		DB25F – KVM cable connector.
RS232		RJ12 6-conductor jack

Table 2. Rear panel connectors

### UltraView Pro Cables

---

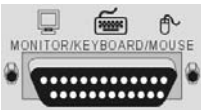
(See Appendix C for cable part numbers)

#### UltraView Pro to KVM station cable

---

The KVM cable connects a keyboard, video monitor, and mouse to the UltraView Pro. The KVM cable is configured with a DB25M connector on one end and a connector for the keyboard, video, and mouse cables on the other end. These KVM cable connectors should be compatible with the types of connectors that are on your KVM stations keyboard, monitor, and mouse cables.

#### UltraView Pro to CPU cables

---

A CPU cable is used to connect each computer to the UltraView Pro. The CPU cable connects from the DB25F CPU ports on the UltraView Pro to the keyboard, video, and mouse ports on each CPU. This cable is configured with a DB25M connector on one end and a connector for the keyboard, video, and mouse on the other end. These CPU cable connectors should be compatible with each CPU's keyboard, video, and mouse port.

#### UltraView Pro master to slave cables

---

In systems needing access to additional CPUs, the UltraView Pro can be cascaded to other UltraView Pros. To cascade an UltraView Pro to other "Slave" units, you will need one DB25M to DB25M, switch-to-switch cable for each slave unit.

(Rose Electronics switch-to-switch cable part number CAB-CXVSMMnnn.)

# INSTALLATION

## Organizing the system

---

It is recommended that before any UltraView Pro configuration or cable connections be made, plan how the system will be laid out, the placement of the CPUs and the placement of the UltraView Pro. Take into consideration the cable lengths needed to connect to the KVM station and each CPU. Identify which CPU will be connected to computer 1's DB25 connector, computer 2, and so on.

The default computer names that the UltraView Pro uses to identify the computer are computer 1, computer 2, and so on. These names can be changed using the on-screen "Configure computer" menu.

## Installation – single unit

---

This section explains how to connect and initially configure the UltraView Pro. If you are cascading two or more UltraView Pro units together, please refer to the Cascade installation section.

NOTE: Some installation procedures and menu selections may not be available on the PC model.

### Step 1. Connecting the keyboard, video monitor, and mouse

---

Connect the KVM stations keyboard, video monitor and mouse cables to the corresponding connectors of the appropriate KVM cable as shown in Figure 3. The KVM cable should have the correct connector types for the equipment used. Connect the DB25M connector into the connector labeled "Monitor/Keyboard/Mouse" on the UltraView Pro rear panel.

### Step 2. Apply power to UltraView Pro

---

For the "M" chassis, connect the power transformer to a 110/220-volt source and to the DIN 5F power adapter connector on the rear panel. Press the ON/OFF button in the front panel once to turn on the unit.

For the "B" and "C" chassis, connect a power cord to 110/220-volt source and to the IEC320 connector on the rear panel. Press the rocker switch to the ON position.

The green POWER LED will turn on and the power-on diagnostic message will display on the KVM monitor. If the KVM monitor is slow to acquire sync, the power-on diagnostic may not be seen.

Computer 1 is automatically connected on power-up. On the front panel, the SELECT 1 LED will light and computer 1's label will display in the lower left corner of the KVM monitor for 5 seconds, then disappear.

### **Step 3. Connecting the computers**

---

(See Figure 3)

Connect each computer to the UltraView Pro using the appropriate CPU cable. Connect the keyboard, video monitor, and mouse connectors of the CPU cable to the corresponding keyboard, video monitor, and mouse ports on the CPU.

Connect the DB25M end of the CPU cable to the DB25F CPU connectors on the rear panel of the UltraView Pro. For ease of installation and configuration, it is recommended that the CPUs be off at this time. When a CPU is booted, the UltraView Pro can automatically determine the keyboard and mouse types of the connected CPU. If the CPUs power needs to be kept on, the UltraView Pro should be pre-configured before the CPUs are connected. (See the configuration menu section)

The UltraView Pro can be pre-configured before any computers are connected. This allows for connecting the computers to the switch while they are powered on and not disrupting service on critical computers. If you need to connect computers while power is still applied to them, configure the switches keyboard and mouse type for each computer first using the configure computer menu, then connect the CPU to the UltraView Pro using the appropriate CPU cable. This procedure should only be performed if the computers being connected with power on can hot switch the keyboard and mouse without locking up the system.

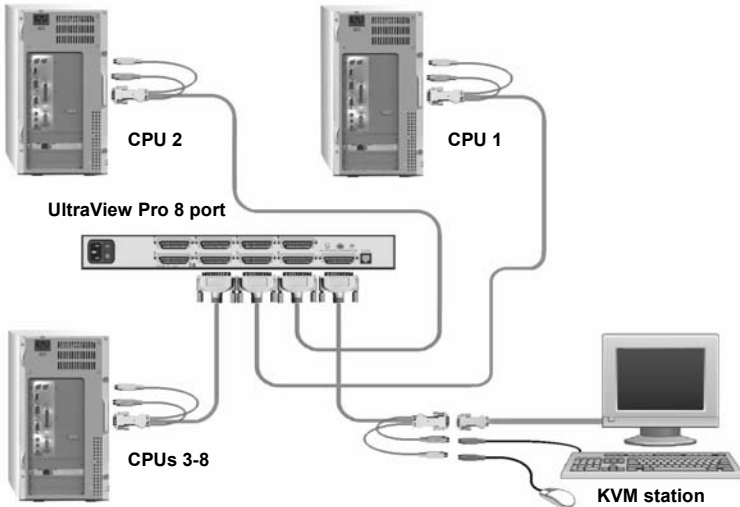

(4 CPUs can be connected using a 4-port unit, 16 using a 16-port unit)

Figure 3. UltraView Pro to CPUs

## Installation - Cascading units

The UltraView Pro units can be cascaded together to expand the number of computers that can be accessed from the KVM station.

When cascading units, one unit becomes the “Master” unit and all others are “Slave” units. Each computer port on the master unit can be connected to a slaves KVM connector. Figure 4 illustrates the addition of two 8-port slave units. Using 16 port units, the master unit can connect to 16 slave units.

The UltraView Pro must be configured to properly manage the cascaded units. The maximum number of computers, the number of slave units connected, and the number of ports (width) on each slave unit must be entered into the menu system and saved. In the example in Figure 4, the maximum computer entry would be 22, the number of slave units is 2, and the number of ports on each slave unit would be 8. It is recommended that all slave units have the same number of computer ports.

It is only necessary for the “Master” unit to be equipped with an OSD. Slave units can be an UltraView or ServeView product without an OSD. All units should have the same or latest firmware revision.

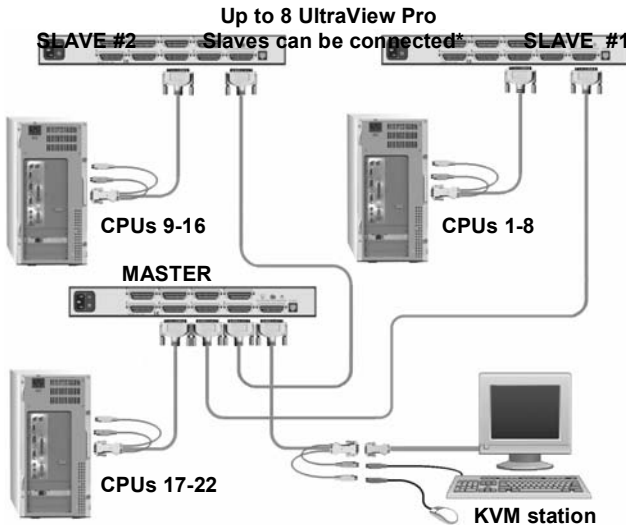

\* 4 units can be cascaded using a 4-port master/16 using a 16-port master

Figure 4. Cascading units

### Slave unit installation

To properly install the slave units, follow the below steps.  
(See the Configure System menu section for detailed instructions)

1. Connect the KVM stations keyboard, monitor, and mouse to the master units Monitor/Keyboard/Mouse connector using the appropriate KVM cable.
2. Connect CPU port #1 on the master unit to the KVM connector on Slave #1 using a DB25 to DB25 expansion cable. (Rose Electronics part number CAB-CXVSMNnnn)
3. Connect the next sequential CPU port on the master unit to the KVM connector on the next sequential Slave unit.
4. Connect the remaining Slave units to the master unit.
5. When all slave units are connected, call up the UltraView Pro's "Main configuration" menu by pressing and releasing the left control <Ctrl> key, then the F12 key. (See Figure 5).
6. Using the up/down arrow keys, select (highlight) "Configure system" and press enter. The "Configure system" menu will display. (See Figure 6)
7. Using the up/down arrow keys, select "Maximum computers" and press enter. Enter the total possible number of computers in the system and press enter.

8. Next, select “Expansion width” from the configure system menu and press enter. Enter the number of computer ports on a slave unit and press enter. This setting determines how many computers are on an expansion unit and determines which computer number is associated with which physical connector. If all expansion units have an equal number of ports, enter the number of ports on one expansion unit for the width number. If there are mixed expansion units with a different number of ports, the width value should be the number of computer ports that is on the expansion unit that has the most computer ports. Care should be taken when mixing slave units. For example, if your system consists of an 8-port master, two 8-port slaves and a one 4-port slave, and you program the expansion width to 8, there will be 4 blind ports on the 4-port unit. If you program the expansion width to 4, then only computers 1-4 on the 8-port slave units can be accessed.
9. Finally, select “Expansion units” and press enter. Enter the total number of slave units in the system and press enter. This command configures how many slave units are connected to the master unit.
10. Press Esc key to return to the main menu and select “Exit” and press enter. You will be prompted to save the changes made. Select “Yes” and press enter to save.

Refer to the configuration menu section for a detailed explanation of each of the configuration menus. The following menus are available.

The “Configure system” menu is for configuring the KVM stations keyboard and mouse, the expansion units, scan settings, and other keyboard settings.

The “Configure computer” menu section allows you to assign a unique name to each of the computers. This makes it easy to identify which computer your switching to. You can also change the CPU keyboard and mouse types from this menu.

The “Configure overlay” menu section allows you to change the general appearance of the on-screen display and other features.

The “Configure security” menu is used to enable a configuration and access passwords. A unique password can be assigned for access to the configuration menus and to restrict computer access.

# CONFIGURATION MENUS

## Main configuration menu

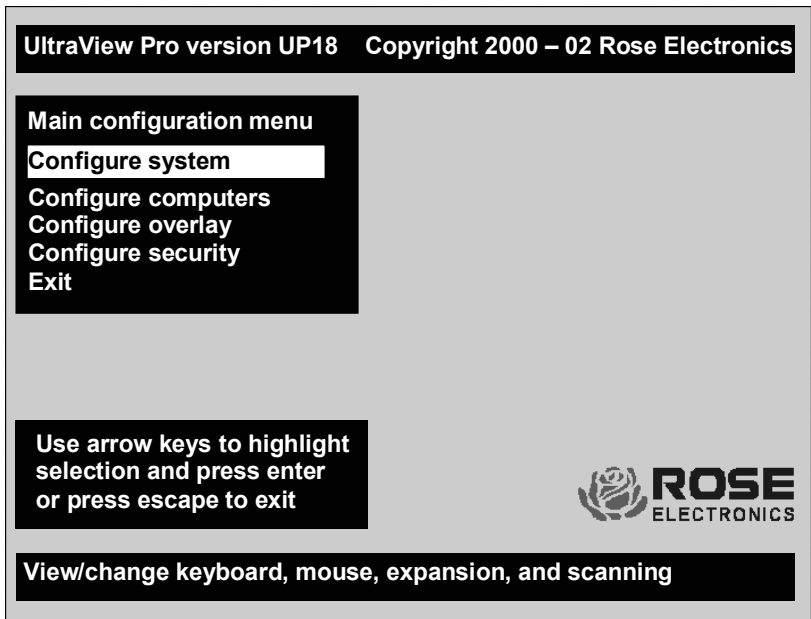

Figure 5. Main configuration menu

The UltraView Pro uses a command to establish communication to the UltraView Pro and not a CPU. This command input is a press and release of the left control <Ctrl> key, then the command. The command must be entered within 2 seconds of pressing and releasing the left control key or the UltraView Pro re-establishes communication with the connected CPU.

The main configuration menu is accessed from the keyboard by pressing and releasing the left control <Ctrl> key and within 2 seconds pressing the F12 key. The main configuration menu will display on the KVM monitor. From this menu, you can configure the system, configure the connected computers, the appearance or overlay of the displayed menus, and assign unique passwords for accessing the configuration menus and a password for accessing the connected computers. Use the up/down arrow keys to select which section menu to configure and press enter.

## Configure system menu

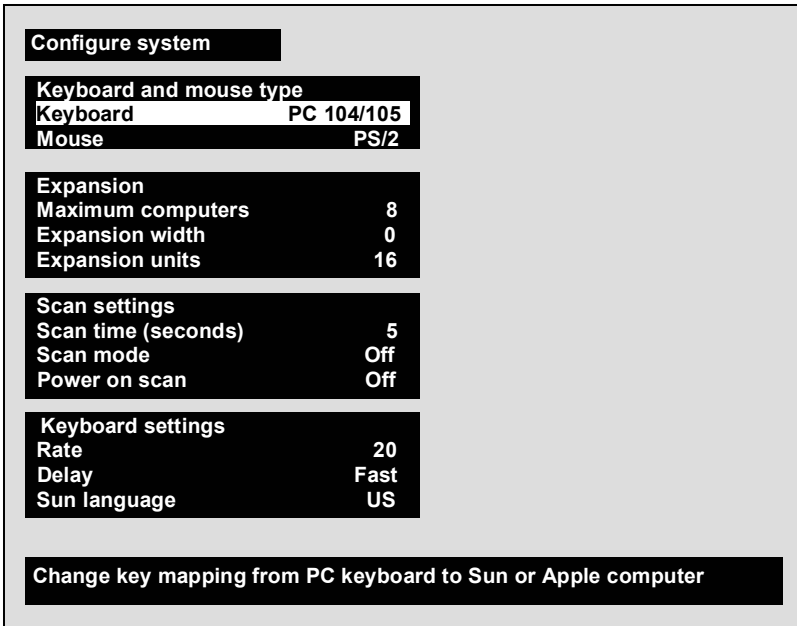

Figure 6. Configure system menu

By selecting "SYSTEM" from the main menu and pressing enter, the "Configure system" menu will display. From this menu, you can configure the KVM stations keyboard and mouse, the expansion information, the scan settings, the keyboard settings or typematic rate, delay and the Sun language settings.

### Keyboard and mouse type (KVM station)

To configure the keyboard or mouse type, use the up/down arrow keys and select keyboard or mouse and press enter. A display box will appear listing the choices for the keyboard or mouse. Use the up/down arrow keys to select the correct keyboard or mouse and press enter. The select choices are:

#### Keyboard choices

101/102  
104/105

#### Mouse choices

PS/2 or PS/2 wheel  
Serial 2-button  
Serial 3-button

## Expansion

---

If your system consists of cascaded units, the expansion section of the Configure System menu must be properly configured to provide the needed information to manage the slave units.

It is recommended that all slave units have the same number of CPU ports. To change the “Maximum computers”, “Expansion width”, and “Expansion units”, use the up/down arrow keys and select the item and press enter. An input box will display for a new value.

### Maximum computers

This setting configures the total number of computers that are connected and provides a wrap around value for scanning and the plus/minus commands. Switching commands are validated against this value for a valid port number. The “Maximum computers” value is the Expansion width value times the number of slave units plus the CPU ports on the master unit that are not used for expansion. Enter the number of connected computers and press enter. Valid entries are 2 to 256.

### Expansion width

The “Expansion width” setting determines how many computers are connected to a slave unit. If the slave units are 4 port units, the width value would be 4. If they are 8 port units, the expansion width value would be 8. If the expansion units are a mixture of 4, 8, and/or 16 port units, the “Expansion width” value is the number of CPU ports on the expansion unit with the greatest number of ports.

### Expansion units

The “Expansion units” setting is the number of slave units that are connected to the master unit. This value determines which computer number is associated with which physical connector. If no expansion units are used, this number should be set to zero. In the example in Figure 4, the “Expansion units” setting to enter would be 2.

## Scan settings

---

The scan settings section determines the amount of time in seconds that a computer’s video is displayed before automatically switching to the next sequential computer. The scan mode can be turned on or off and set to automatically scan the computers when the UltraView Pro is powered up.

### Scan time (seconds)

To change the scan time, highlight “Scan time” and press enter. An input box will display for a new value. Enter the new scan time in seconds and press enter. Valid entries are 1 to 999.

### Scan mode

This value turns scanning on or off. To change this value, select “Scan mode” and press enter. An input box will appear. Select “On” or “Off” and hit enter.

### Power on scan

Setting this value to “On” will enable scanning when the UltraView Pro is powered on. To change this value, select “Power on scan” and hit enter. Use the up/down arrow keys to select “OFF” or “ON” and press enter.

## Keyboard settings

---

The keyboard setting section of the configure system menu is used to change the typematic rate and delay for PC keyboards and also to set the language type for Sun keyboards.

### Rate (keys/sec)

To change the rate value, highlight “Rate (keys/sec)” and press enter. An input box will appear. Choose the rate value from Table 3 that represents the Rate keys/sec needed and press enter.

Rate Keys/ Sec.	Rate Value	Rate Keys/ Sec.	Rate Value	Rate Keys/ Sec.	Rate Value	Rate Keys/ Sec	Rate Value
30.0	31	15.0	23	7.5	15	3.7	7
26.7	30	13.3	22	6.7	14	3.3	6
24.0	29	12.0	21	6.0	13	3.0	5
21.8	28	10.9	20	5.5	12	2.7	4
20.0	27	10.0	19	5.0	11	2.5	3
18.5	26	9.2	18	4.6	10	2.3	2
17.1	25	8.6	17	4.3	9	2.1	1
16.0	24	8.0	16	4.0	8	2.0	0

Table 3. Typematic rate

## Delay

This setting is for PC keyboards only. It is used to adjust how long, after a key is depressed and held, that key starts to repeat. To change the delay value, select “Delay” and press enter. A list box will display showing the choices available. Use the up/down arrow keys to select the delay rate wanted and press enter.

The choices are:

- Slow (1 second)
- Medium (750 ms.)
- Fast (500 ms.)
- Fastest (250 ms.)

## Sun Language

If the Sun keyboard type you are using is not a US Sun keyboard, the language can be changed to the correct language keyboard. To change the language type, select “Sun Language” and press enter. A list box will display showing the language choices available. Use the up/down arrow keys to select the correct Sun Keyboard language and press enter.

The choices are:

- |              |              |
|--------------|--------------|
| ■ US         | ■ Spanish    |
| ■ US Unix    | ■ Swed/Finn  |
| ■ French     | ■ SWFrench   |
| ■ Danish     | ■ SWGerman   |
| ■ German     | ■ UK         |
| ■ Italian    | ■ Korean     |
| ■ Neth/Dutch | ■ Taiwan     |
| ■ Norwegian  | ■ Japan      |
| ■ Portuguese | ■ FrCanadian |

## Configure computer menu

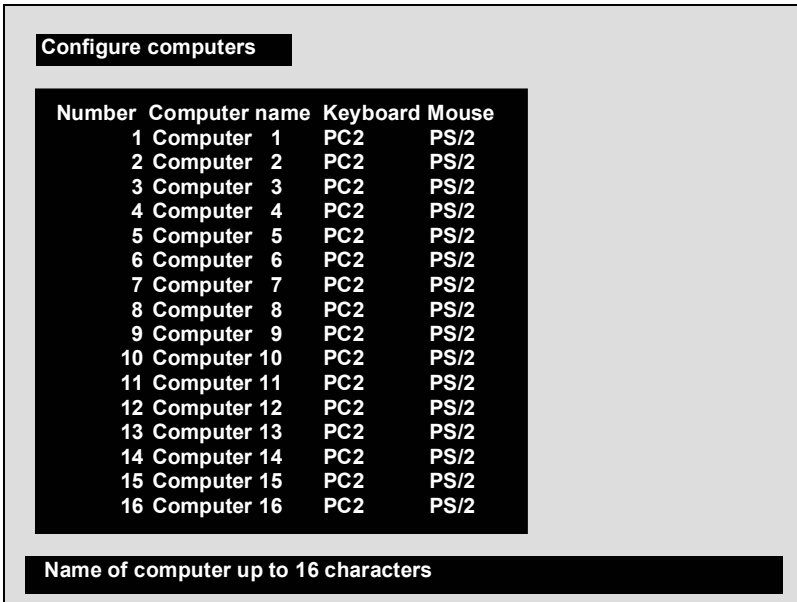

Number	Computer name	Keyboard	Mouse
1	Computer 1	PC2	PS/2
2	Computer 2	PC2	PS/2
3	Computer 3	PC2	PS/2
4	Computer 4	PC2	PS/2
5	Computer 5	PC2	PS/2
6	Computer 6	PC2	PS/2
7	Computer 7	PC2	PS/2
8	Computer 8	PC2	PS/2
9	Computer 9	PC2	PS/2
10	Computer 10	PC2	PS/2
11	Computer 11	PC2	PS/2
12	Computer 12	PC2	PS/2
13	Computer 13	PC2	PS/2
14	Computer 14	PC2	PS/2
15	Computer 15	PC2	PS/2
16	Computer 16	PC2	PS/2

Name of computer up to 16 characters

Figure 7. Configure computer menu

The “Configure computer” menu allows you to assign unique names to each computer and change the keyboard and mouse type for each connected computer. Use the page up/down keys if there are more than 16 computers connected in the system.

### Computer name

The name of the connected computers can be changed from computer x to any name up to 16 valid ASCII characters. Assigning a unique name to each computer gives you the ability to know what computer you are connecting to without having to remember or use a cross-reference list.

To change the computer name, select the “Computer name” to change and press enter. An input box will display. Enter the new computer name and press enter.

## Keyboard

To change a computers keyboard and/or mouse, use the up/down arrow keys to select (highlight) which computer to change the keyboard or mouse. Use the left/right arrow keys to select either the keyboard or mouse to change and press enter.

A window will appear listing the keyboard or mouse types available. Use the up/down arrow keys and select the correct keyboard or mouse type needed for the selected computer and press enter. The keyboard or mouse type will change to the new type.

USB keyboards for PC and Sun computers are fully supported. If the system uses USB keyboards, they must be set-up from the configure computer menu.

Save the changes when finished configuring each computer.

The keyboard and mouse selections are:

### Keyboard choices

- PC1
- PC2
- PC3
- USB-PC
- USB-Sun
- Apple\*
- Sun\*

### Mouse choices

- PS/2
- PS/2 wheel
- Serial 2-button
- Serial 3-button

\* Available on multi-platform models only.

## Configure overlay

Configure overlay	
<b>Miscellaneous</b>	
Color scheme	Aquarium
Resolution	PC1 640x480x60Hz
Screen saver	Black screen
Screen saver time (seconds)	0
<b>Computer select window</b>	
Background color	Transparent blue
Text color	White
Position	x = 3 y = 3
<b>Computer label</b>	
Background color	Transparent magenta
Text color	Yellow
Position	x = 3 y = 90
Show computer number	Yes
Fade out (seconds)	20
Font	16x32 classic
<b>Colors of the configuration menu</b>	

Figure 8. Configure overlay menu

The “Configure overlay” menu is used to configure the color of the menus, the resolution of the video when no computer video is present, the screen saver type and time, the computer select window appearance, and the displayed computer label. The “Configure overlay” menu is accessed by first calling up the main configuration menu (<Ctrl>, F12), and then selecting “Configure overlay” and pressing enter.

### Configure overlay - Miscellaneous

#### Color scheme

The default setting is Aquarium. To change this, select “Color scheme” and press enter. A selection box will appear listing the 4 choices. Use the arrow keys to select a scheme and press enter. The choices are:

- Aquarium - cyan, magenta, white, and blue
- Tuxedo - black, red, and white
- Night sky - blue, black, and white
- Forest - green, black, cyan, and blue

## Resolution

Use this configuration to set the resolution for the KVM stations video if no computer video is present. To change the setting, select “Resolution” and press enter. A selection box will appear listing the choices.

The default setting is PC2, 640 x 480 @ 60Hz.

DO NOT select a setting that the KVM monitor cannot support

The choices are:

- PC1      1640 x 480 @ 60Hz
- PC2      640 x 480 @ 72Hz
- PC3      640 x 480 @ 75Hz
- MAC1\*    640 x 480 @ 67Hz
- MAC2\*    832 x 624 @ 75HZ
- SUN1\*    1152 x 900 @ 66Hz
- SUN2\*    1152 x 900 @ 76Hz
- HV\*      640 x 480 @ 66Hz
- CS\*      1152 x 900 @ 66Hz

\* Available on multi-platform models only.

## Screen saver

This feature activates a screen saver when there is no keyboard or mouse activity for a specified time period. To change the setting, select “Screen saver” and press enter. A selection box will appear listing the 4 types of screen savers that are available. Use the up/down arrow keys to select a new screen saver and press enter. The default screen saver is Fireflies.

The choices are:

- Black screen
- Fireflies
- Weaving
- Bounce

## Screen saver time (seconds)

This sets the time the screen saver activates when no keyboard or mouse activity is present. To change the time, select the item and press enter. An input box will display to enter a new value. Valid entries are 0 to 999 seconds. A value of 0 disables the screen saver function.

## Configure overlay - Computer select window

---

The “Computer select window” section allows you to change the background and text colors of the computer select window, and the text position on the screen.

Use the up/down arrow keys to select the item to configure and press enter.

DO NOT set the background and text colors the same.

### Background color

To change the background color, select “Background color” and press enter. A color selection box will display showing the available background colors. Use the arrow keys to select either a solid or transparent color and press enter.

The default background color is Transparent blue.

The choices are:

#### Solid colors

- Black
- Red
- Green
- Yellow
- Blue
- Magenta
- Cyan
- White

#### Transparent colors

- Clear
- Red
- Green
- Yellow
- Blue
- Magenta
- Cyan
- White

### Text color

To change the text color, select it and press enter. A color selection box will display showing the available text colors. Use the arrow keys to select either a solid or transparent color and press enter.

The default text color is white. The color choices are the same as the background selections.

## Computer label

---

The “Computer label” section allows you to customize the display of the computer label. The colors, position, fade out time, font and whether the computer number is displayed.

## **Background color**

To change the background color, select “Background color” and press enter. A color selection box will display showing the available background colors. Use the arrow keys to select either a solid or transparent color and press enter. The default background color is Transparent blue. The choices are the same as the background colors for the computer select window.

## **Text color**

To change the text color, select it and press enter. A color selection box will display showing the available text colors. Use the arrow keys to select either a solid or transparent color and press enter. The default text color is white. The choices are the same as the background colors for the computer select window

## **Position**

This item sets the position of the computer label window on the display screen. This position is maintained at all screen resolutions. To change the position, select “Position” and press enter. The overlay page will disappear and a label box will display. Use the arrow keys to move the label box anywhere on the screen. Press enter when the desired position is reached. The screen position values are entered automatically into the x (horizontal) and y (vertical) fields. Setting the position off the edge of the screen may cause an out of sync image. Valid entries are 0 – 64 (horizontal) and 0 – 99 (vertical).

## **Show computer number**

This sets whether the computer number and computer name are displayed on the KVM stations monitor when a computer is selected. Select this item and press enter. A YES/NO box will display. Use the up/down arrow keys and select either YES or NO and press enter.

## **Fade out (seconds)**

This controls how long the computer label displays before disappearing. A value of zero (0) disables this function and the label will not be displayed. A value of 255 causes the computer label to always be displayed. To change this value, select it and press enter. An input box will display for a new value. Enter the value wanted between 0 and 255 and press enter. (<Ctrl> D, <Enter> will display the label at any time)

## **Font**

This item sets the font type for the computer label. To change the font, select “Font” and press enter. Use the up/down arrow keys to select a new font type and press enter.

The font choices are:

- 8 x 16 modern      The actual size of the font will vary depending on the resolution of the video.
- 8 x 16 classic      As the resolution increases, the fonts become smaller.
- 16 x 24 modern
- 16 x 24 classic
- 16 x 32 modern      The modern font is sans-serif, the classic is similar to Times.
- 16 x 32 classic

## Configure security

---

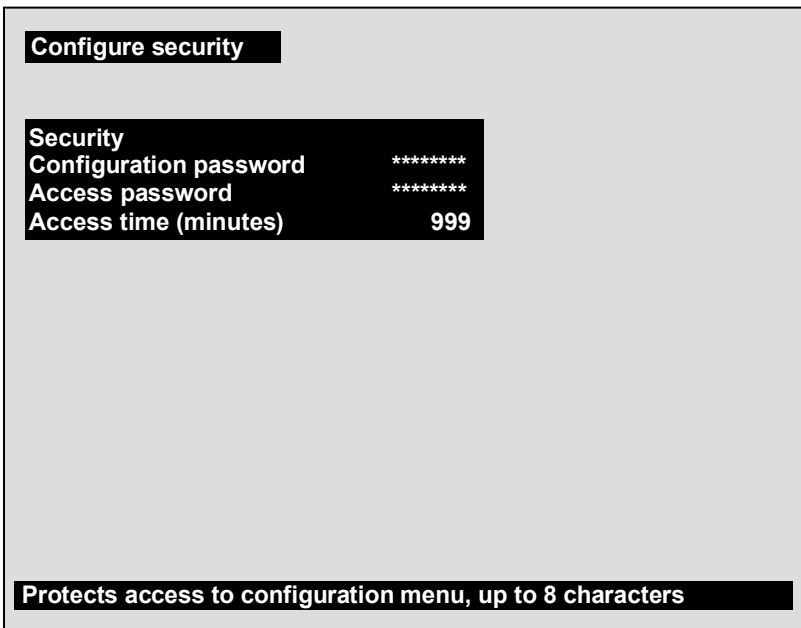

Figure 9. Configure security

The “Configure security” menu allows for setting a configuration password and an access password. The configuration password restricts access to the configuration menus and the access password limits access to the connected computers.

## **Configuration password**

To assign a “Configuration password”, select it from the “Configure security” menu and press enter. An input box will appear. Type in the desired configuration password (case sensitive, 8 chars/max) and press enter. A confirmation box will display, re-type the password and press enter. When the password is saved, the next time the configuration menu is called up (<Ctrl>, F12), this password must be entered.

## **Access password**

This feature is used to restrict unauthorized access to the connected computers. To assign an access password, select it from the menu and press enter. Enter this password the same way as you entered the configuration password. When the UltraView Pro is powered on or if you disconnect from a computer, a login box will display requesting the access password.

## **Access time (minutes)**

The access time setting is used to automatically log out of a switch after the set time period. When there is no keyboard or mouse activity for this time setting, the user is automatically logged out. To change this value, select it from the menu and hit enter. An input box will display for a new access time value. Enter the new time in minutes and hit enter. Valid times are 1 to 999 minutes.

## **Logging off the system**

To log off the system and lock the keyboard enter <Ctrl> and the L key to disconnect from the switch. To gain access to the connected computers, an access password must be entered if one has been assigned.

## **Resetting the passwords**

The passwords can be reset if they are ever forgotten. To reset them, first turn off the UltraView Pro and disconnect the power cord or power adapter. Carefully remove the top chassis cover exposing the PCB. Put a jumper on the two pins labeled “Password reset jumper” and power on the switch. Call up the configure security menu and enter a new configuration password, access password and access time. Press <Esc> to return to the main menu. Select “Exit” and press enter. You will be prompted to save the changes. Select “YES” and press enter. The new password settings will be saved in flash memory. Next, turn off the UltraView Pro and remove the installed jumper. Replace the top chassis cover and power the switch back up. The new passwords will be active after power is applied.

## OPERATION

### Selecting a computer

---

To connect to a computer, you can select it from the UltraView Pro's front panel, select it by keyboard commands, select it through the RS232 serial port, or you can select the computer from a computer select window as shown in Figure 10.

#### Selecting a computer from the front panel

---

Using the + and – buttons on the front panel will advance (+) or switch to the previous (-) computer port.

#### Selecting a computer using keyboard commands

---

Press and release the left control <Ctrl> key, then enter the computer port number. Pressing and releasing the left control <Ctrl> key then the “+” or “-“ key will advance forward or backwards one sequential port.

#### Selecting a computer through the RS232 port

---

Selecting a computer can be done through the RS232 port if needed. Contact Rose Electronics Technical support for details.

#### Selecting a computer using the Computer select window

---

Press and release the left control <Ctrl> key, then press Esc. The computer select window will display. Use the up/down arrow keys and select the computer to switch to and press enter. You will be immediately connected to that computer. Use the page up/down keys if there are more than 16 computers in your system.

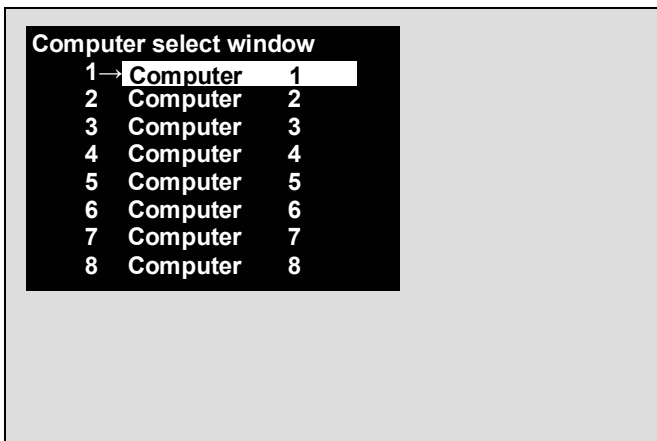

Figure 10. Computer select window

## KEYBOARD COMMANDS

### Keyboard commands

The following table describes the available keyboard commands. The <Ctrl> key sequence is a press and release of the left control key. Commands following <Ctrl> must be entered within 2 seconds.

Command	Key sequence	Description
OSD menu	<Ctrl> F12	Displays on-screen menus
CPU select	<Ctrl> ESC	List of CPUs to select
Select computer	<Ctrl> nnn where nnn = computer number	Connects the KVM station to the selected computer.
Next computer	<Ctrl> +	Selects next sequential CPU
Previous computer	<Ctrl> -	Selects previous sequential CPU.
Scan ON	<Ctrl> S	Turns scan mode on
Scan OFF	<Ctrl> X	Turns scan mode off
Display label	<Ctrl> D	Turns CPU label on/off
Logoff	<Ctrl> L	Disconnects from currently connected computer.
Set mode	<Ctrl> Mnn <Enter> where nn = mode value from Table 5.	Alternate way to configure keyboard and mouse.
Set resolution	<Ctrl> Yn <Enter> where n = resolution value from Table 6	Alternate way to set screen resolution when no video is present from a CPU..
Screen saver time	<Ctrl> Vnnn <Enter> where n = 0 –999 sec.	Alternate way to set screen saver time.
Null mouse command	<Ctrl> N	Used to re-sync a PS/2 mouse.
Reset mouse	<Ctrl> O (alpha O)	Resets computer's mouse.
Reset command	<Ctrl> R	Resets and enables mouse and keyboard on currently selected computer
Max computers	<Ctrl> Pnnn	Total ports used (all units)
Units	<Ctrl> Unn	Number of expansion units.
Width	<Ctrl> Wnn	Number of ports on expansion units.
Keep	<Ctrl> K	Saves to flash memory.

Table 4. Keyboard commands

Mode value	Description
M1	CPU keyboard = PC mode 1 (Some IBMs & PS/1's)
M2	CPU keyboard = PC mode 2 (Most PCs)
M3	CPU keyboard = PC mode 3 most (RISC) Unix w/stations
M4	CPU keyboard/mouse = Apple ADB
M5	CPU keyboard/mouse = Sun
M6	CPU mouse = PS/2 mouse – any brand
M7	CPU mouse = 2-button serial (Microsoft - 7 bit)
M8	CPU mouse (Reserved for future use)
M9	CPU mouse/= 3- button serial (Mouse systems)
M10	CPU mouse = PS/2 wheel
M11	CPU Keyboard/mouse = USB-PC
M12	CPU Keyboard/mouse = USB-Sun
M20	Keyboard = PC – 101/102- PC
M21	Keyboard = PC – 104/105-PC Win95
M30	Mouse = PS/2 or PS/2 wheel
M31	Mouse= Serial 2-button (7 bit-Microsoft)
M32	Mouse = Serial 3-button (8-bit – not used)
M33	Mouse = Serial 3-button (Mouse systems)
M40	Keyboard & mouse - Set all ports to Apple ADB
M50	Keyboard & mouse - Set all ports to Sun
M60	Keyboard & mouse - Set all ports to PC2 kbd/PS/2 mouse

Table 5. Mode command values

Value	TYPE	Resolution
Y1	PC1	640 x 480 @ 60Hz
Y2	PC2	640 x 480 @ 72Hz
Y3	PC3	640 x 480 @ 75Hz
Y4	Mac1	640 x 480 @ 67Hz
Y5	Mac2	832 x 624 @ 75Hz
Y6	Sun1	1152 x 900 @ 66Hz
Y7	Sun2	1150 x 900 @ 76Hz
Y8	HV*	640 x 480 @ 66Hz
Y9	CS*	1152 x 900 @ 66Hz

Table 6. Resolution command values

\* Available on multi-platform model only

## Keyboard command usage

---

When using keyboard commands to enter information to the UltraView Pro, please observe the following guidelines to avoid entering incorrect values or no values.

1. All commands start with a press and release of the left control key.
2. Commands following the press and release of the left control key must be entered within 2 seconds or control reverts to the connected computer and the command will be sent to that computer and not the UltraView Pro.
3. Use only the numeric keys above the keyboard and not the numeric keypad.
4. Letter commands such as <Ctrl> L are not case sensitive and are only shown in uppercase for clarity. Do not use the shift key to enter letter commands.
5. To connect to the next or previous computer, the keyboard command is <Ctrl> + or <Ctrl> -. The plus and minus keys on the keypad will connect to the next or previous computer. The + and – keys on the keyboard, next to the backspace key vary from country to country as to their usage. These keys can still be used to connect to the next or previous computer.

## Reset to factory defaults

---

To reset the UltraView Pro to the original factory default settings, first, power down the unit, press and hold the – (minus) switch in and turn the power on to the unit. Keep the – (minus) switch held in until the unit switches to the last port on the unit (port 4, 8, or 16). If you release the – (minus) switch before the last port is switched to, the defaults will not be restored. The configuration and access passwords are not reset using this procedure.

## Rackmounting

---

The UltraView Pro can be rack mounted using a Rose Electronics Rackmount kit. See Appendix D and E for instructions.

### Serial Port (RS232)

---

The RS232 serial port on the UltraView Pro's rear panel is used for sending switching commands from a stand-alone computer or terminal or to load flash firmware upgrades to the unit. A serial cable and an RJ to DB9 adapter are included with the unit. Perform steps 1-3 below to use the serial port.

1. Connect the serial cable to the RS232 serial port on the rear panel of the UltraView Pro and to the RJ12 connector on the adapter.
2. Connect the DB9 connector on the adapter to the stand-alone computer or terminals DB9 COM port.
3. Set the computers communication program for:
  - a. 9600 baud
  - b. no parity
  - c. 8 bits
  - d. 1 stop-bit

To switch to a computer port on the UltraView Pro from a stand-alone computer or terminal, enter the 1-3 digit port number to switch to followed by enter. To switch to computer port 2, you would type in the number 2 then enter. This switches the KVM station to computer port 2 and displays that computers video on the KVMs monitor.

### Firmware update

---

The UltraView Pro's flash memory can be updated with the latest firmware using the RS232 serial port. Updates can be obtained from Rose Electronics web site at [www.rose.com](http://www.rose.com) under the support section. Verify the unit's program and kernel versions against the current versions on our web site. This information is listed on the diagnostic screen when the unit is first powered up (See Figure 11). The program version can be displayed by starting a word processor program on the KVM station like word or notepad or switching to the command prompt and typing in <Ctrl> and I key.

The latest firmware file names on Rose Electronics web site are: UPPxx.hex – main program and UPKxx.hex – kernel program. (xx = the revision number)

To update the UltraView Pro's firmware, first download the latest revision from Rose Electronics web site and save it to a stand-alone computer that is not connected to the UltraView Pro. Connect the serial cable from the UltraView Pro to the serial port of the stand-alone computer as described in steps 1-3. There are two methods of loading the downloaded programs to flash memory.

### **Method 1 – Using a communication program**

1. Press both the - and + switches on the front panel and power on the UltraView Pro. LED 1 will light indicating the unit is ready to accept the upgrade file at 9600 baud. To use 57600 baud rate, press the + switch and LED 1 will turn off and LED 4 will light.
2. Run your communication program. Set the baud rate to the correct rate and put the program in direct connect mode. When the - or + switch is pressed, you should see the message:  
"Waiting for file at 9600 or 57600 baud."
3. Send the file to the unit using a simple ASCII text file protocol. While the file is being sent, periods are sent to indicate the file copy progress. Once the file has been sent, you should see the following message:  
"Receive successful"  
"Hit space to program"
4. Hit the space bar to start programming the flash memory. The programming and verifying progress is indicated by sending periods. You should see the following message:  
"Programming flash"  
  
.....  
"Verifying flash"  
  
.....  
"Verify successful"  
"Hit enter to boot"
5. Hit enter and the UltraView Pro will re-start with the new firmware. This can be verified by the diagnostic information displayed on the KVM monitor.
6. Hit the enter key to continue. The UltraView Pro is now operational with the new firmware update.

If the upgrade is not successful, you will see one of the following error messages:

- Checksum error or Record error or Data error
- Receive failed  
Try again Y/N?

If any of these errors occur, check the RS232 cable, the connectors, and the adapter. Make sure they are in good working order. Verify the communication program is configured correctly. Enter “Y” to try upgrading the flash again. If programming is unsuccessful, the unit should be serviced.

**Method 2 – Using the front panel switches with a file copy.**

1. Press both the - and + switches on the front panel and power up the UltraView Pro. The UltraView Pro is ready to accept the upgrade file. LED 1 will light indicating the unit is set at 9600 baud. To use 57600 baud, press the + switch, LED 4 will light. Copy the file to the unit. While the file is being copied LED 1 or 4 will flash. Once the file is copied, LED 2 will light.
2. Press and release the + switch, LED 2 flashes off for a brief instant. The flash is now being programmed and verified. LED 3 now lights.
3. Press and release the + switch, LED 3 flashes off for a brief instant. The new firmware is now run and diagnostic information is sent to the on-screen display. Observe the new revision number matches that of the file. LED 4 now lights.
4. Press and release the + switch. LED 1 now lights. The box is now operational and port 1 is selected or the login box is waiting for its password. The flash loading procedure is complete.

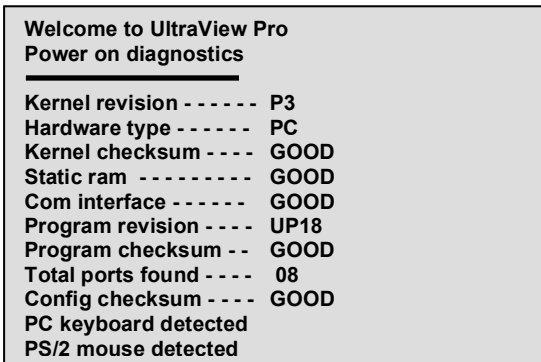

Figure 11. Power-on diagnostic screen

### TROUBLESHOOTING

---

#### **Computer does not boot, keyboard or mouse error received.**

- Cable is loose, reseal cable and on PC hit F1 to continue or reboot computer.
- Wrong cable or keyboard and mouse cables reversed.
- Cable is defective; try using cable from another computer.
- Port on the UltraView Pro is defective; try using another port on UltraView Pro. If the problem goes away port is defective.
- Port on computer is defective, try plugging in keyboard or mouse directly if problem remains computer port is defective. If power status LED not lit, fuse on motherboard may be blown.
- Computer keyboard and mouse not configured.

#### **Mouse driver does not load.**

- If PS/2 type mouse, computer must be connected to UltraView Pro or mouse at boot-up time in order for mouse to be recognized by the computer. Reboot computer with UltraView Pro powered on and cable attached.
- If RS232 type mouse, make sure right COM port is being used and syntax of mouse driver is correct to search for the correct port.
- Computer keyboard and mouse not configured.

#### **Can't switch computers from keyboard**

- Power to the UltraView Pro was removed for less than three seconds possibly causing keyboard to lock up. Disconnect and re-connect the keyboard.
- If PS/2 type keyboard and mouse cables may be reversed.
- Not using left control key. Using numeric keypad instead of keys on top row. Not releasing control key before typing in number. Waiting more than 2 seconds to enter computer number. Using caps lock or shift key.

#### **Wrong or missing characters from those typed**

- For PCs, the mode of the keyboard does not match that of the computer. Issue the mode command, usually 1 for IBM PS/2s, 3 for Unix computers, and 2 for all others. The default setting is mode 2. Sometimes an incorrect mode will confuse the computer or keyboard and require re-booting the computer or resetting the keyboard by unplugging and plugging it back in.

#### **Switch to Switch failure**

- Verify the firmware in all like switches is the same revision.

### **Mouse does not move**

- Mouse not configured.
- UltraView Pro turned off after or not connected when computer booted or application using mouse run. Exit and re-enter application using mouse or issue reset command.
- PS/2 mouse was not connected when UltraView Pro powered up or disconnected and reconnected. Issue the reset command or reconfigure the mouse.

### **PS/2 mouse gets out of sync**

- Cabling was disturbed during mouse movement. Issue the null command once or twice to re-sync the mouse. Update mouse driver. Try using ctrl O command to recover if O/S is NT.
- Sun keyboard needs to be reset, with unit power on, disconnect and re-connect the sun keyboard.

### **Video fuzzy**

- Cable too long or wrong type. Verify that resolution and distance match. See Appendix G. Upgrade cable if necessary.

### **Video not synchronized or wrong color**

- Cable is loose, reseal cable.
- Monitor not capable of syncing to video selected, upgrade monitor.
- Cable is defective; try using cable from another computer if problem goes away cable is defective.
- Port on UltraView Pro is defective; try using another port on UltraView Pro. If problem goes away port is defective.

### **Lower resolution OK, but can't enter high resolution mode**

- Video driver has not been setup for this resolution. Configure the driver.

### **Slave unit does not switch**

- Maximum ports command not issued.
- Width or units command not configured properly. Reconfigure them to match number of computers and how they are connected.

### **On-screen display not synchronized**

- No video from computer or resolution setting not configured correctly.

### Service Information

---

#### Maintenance and Repair

---

This Unit does not contain any internal user-serviceable parts. In the event a Unit needs repair or maintenance, you must first obtain a Return Authorization (RA) number from Rose Electronics or an authorized repair center. This Return Authorization number must appear on the outside of the shipping container. See Limited Warranty for more information.

When returning a Unit, it should be double-packed in the original container or equivalent, insured and shipped to:

Rose Electronics  
Attn: RA \_\_\_\_\_  
10707 Stancliff Road  
Houston, Texas 77099 USA

#### Technical Support

---

If you are experiencing problems, or need assistance in setting up, configuring or operating your switch, consult the appropriate sections of this manual. If, however, you require additional information or assistance, please contact the Rose Electronics Technical Support Department at:

Phone: (281) 933-7673  
E-Mail: [TechSupport@rose.com](mailto:TechSupport@rose.com)  
Web: [www.rose.com](http://www.rose.com)

Technical Support hours are from: 8:00 am to 6:00 pm CST (USA), Monday through Friday.

Please report any malfunctions in the operation of this Unit or any discrepancies in this manual to the Rose Electronics Technical Support Department.

## Safety

---

This UltraView Pro KVM switch has been tested for conformance to safety regulations and requirements, and has been certified for international use. Like all electronic equipment, the UltraView Pro should be used with care. To protect yourself from possible injury and to minimize the risk of damage to this Unit, read and follow these safety instructions.

- Follow all instructions and warnings marked on this Unit.
- Except where explained in this manual, do not attempt to service this Unit yourself.
- Do not use this Unit near water.
- Assure that the placement of this Unit is on a stable surface or rack mounted.
- Provide proper ventilation and air circulation.
- Keep power cord and connection cables clear of obstructions that might cause damage to them.
- Use only power cords, power transformer and connection cables designed for this Unit.
- Use only a grounded (three-wire) electrical outlet.
- Keep objects that might damage this Unit and liquids that may spill, clear from this Unit. Liquids and foreign objects might come in contact with voltage points that could create a risk of fire or electrical shock.
- Operate this unit only when the cover is in place.
- Do not use liquid or aerosol cleaners to clean this Unit. Always unplug this Unit from its electrical outlet before cleaning.
- Unplug this Unit from the electrical outlet and refer servicing to a qualified service center if any of the following conditions occur:
  - The power cord or connection cables is damaged or frayed.
  - The Unit has been exposed to any liquids.
  - The Unit does not operate normally when all operating instructions have been followed.
  - The Unit has been dropped or the case has been damaged.
  - The Unit exhibits a distinct change in performance, indicating a need for service.

## Safety and EMC Regulatory Statements

---

### Safety Information



Documentation reference symbol. If the product is marked with this symbol, refer to the product documentation to get more information about the product.

**WARNING** A WARNING in the manual denotes a hazard that can cause injury or death.

**CAUTION** A CAUTION in the manual denotes a hazard that can damage equipment.

Do not proceed beyond a WARNING or CAUTION notice until you have understood the hazardous conditions and have taken appropriate steps.

### Grounding

These are Safety Class I products and have protective earthing terminals. There must be an un-interruptible safety earth ground from the main power source to the product's input wiring terminals, power cord, or supplied power cord set. Whenever it is likely that the protection has been impaired, disconnect the power cord until the ground has been restored.

### Servicing

There are no user-serviceable parts inside these products. Only service-trained personnel must perform any servicing, maintenance, or repair.

Only items mentioned in this manual may be adjusted by the user.

## Informations concernant la sécurité



Symbole de référence à la documentation. Si le produit est marqué de ce symbole, reportez-vous à la documentation du produit afin d'obtenir des informations plus détaillées.

### **WARNING**

Dans la documentation, un WARNING indique un danger susceptible d'entraîner des dommages corporels ou la mort.

### **CAUTION**

Un texte de mise en garde intitulé indique un danger susceptible de causer des dommages à l'équipement.

Ne continuez pas au-delà d'une rubrique WARNING ou CAUTION avant d'avoir bien compris les conditions présentant un danger et pris les mesures appropriées.

Cet appareil est un produit de classe I et possède une borne de mise à la terre. La source d'alimentation principale doit être munie d'une prise de terre de sécurité installée aux bornes du câblage d'entrée, sur le cordon d'alimentation ou le cordon de raccordement fourni avec le produit. Lorsque cette protection semble avoir été endommagée, débrancher le cordon d'alimentation jusqu'à ce que la mise à la terre ait été réparée.

Aucune pièce contenue à l'intérieur de ce produit ne peut être réparée par l'utilisateur.

Tout dépannage, réglage, entretien ou réparation devra être confié exclusivement à un personnel qualifié.

## APPENDICES

### Appendix A. Initial factory settings

---

Setting	Default value
KVM keyboard/mouse type	PC – PS/2
CPU keyboard/mouse type	PC – PS/2
Computer names	Computer xxx
Scan time interval	5 seconds
Power on scan	Off
Typematic rate	20 (10.9 chars/sec.)
Typematic delay	Fast (500 milliseconds)
Maximum ports	Same as physical number of ports
Expansion width	16
Expansion units	0
Color scheme	Aquarium
Resolution	640 x 480 @60Hz
Screen saver	Fireflies
Screen saver timeout	0 seconds
Computer select background color	Transparent blue
Computer select text color	White
Computer select position	X=3, Y=3
Computer label background color	Transparent blue
Computer label text color	White
Computer label position	X=3, Y=90
Show computer number	YES
Fade out	5 seconds
Font	16 x 24 modern
Caps/Numlock/Scroll	Numlock On

## Appendix B. Parts and cables

Part number	Description
CAB-CX0606Mnnn**	Coax VGA-PS/2 Kbd-PS/2 mouse to DB25M
CAB-WX0606Mnnn*	VGA-PS/2 Kbd-PS/2 mouse to DB25M
CAB-CX0509Mnnn**	Coax VGA-AT Kbd-Serial mouse to DB25
CAB-VX0509Mnnn*	VGA-AT Kbd-Serial mouse to DB25M
CAB-CXV0800Mnnn**	Coax VGA-Sun Kbd-Sun mouse
CAB-SBX0800Mnnn**	Coax Sun video-Kbd-mouse to DB25M
CAB-C1V0400Mnnn**	Coax Apple video-Kbd-mouse to DB25M
CAB-AV0400Mnnn*	Apple video-Kbd-mouse to DB25M
CAB-CX0606Cnnn**	Coax VGA-PS/2 Kbd-PS/2 mouse to DB25M
CAB-WX0606Cnnn*	VGA-PS/2 Kbd-PS/2 mouse to DB25M
CAB-CX0606Cnnn**/AT	Coax VGA-AT Kbd-Serial mouse to DB25
CAB-WX0606Cnnn*/AT	VGA-AT Kbd-Serial (9) mouse to DB25M
CAB-CXV0800Cnnn*	SUN w/ VGA (HD15) Monitor, SUN Kbd & Mouse
CAB-SCX0800Cnnn**	Coax Sun CPU video Kbd-mouse to DB25M
CAB-C1V0400Cnnn*	Coax Apple video-Kbd-mouse to DB25M
CAB-AV0400Cnnn*	Apple CPU video-Kbd-mouse to DB25M
CAB-CXVSMMnnn*	Expansion Cable
KIT-ATRX	RS232 Cable & DB9 to RS232 adapter
TFR-08D150FSUD	Power transformer for "M" chassis

\* Cable lengths in 1, 5, 10, 20 /(Hi Res.) 35, 50, 75, 100 feet

\*\* Cable lengths in 5, 10, 20, /(Hi Res.) 35, 50, 75, 100 feet

### Rackmount Kit

Chassis size	19 inch	23 inch	24 inch
"M" (mini)	RM-UM19	RM-UM23	RM-UM24
"B" (low)	RM-UB19	RM-UB23	RM-UB24
"C" (high)	RM-UC19	RM-UC23	RM-UC24

## Appendix C. General Specifications

The UltraView Pro part number is Uxy-zUB

Where x = platform, E = PC, SUN, Apple, Unix (Multi-platform)

P = PC and Unix computers (PC)

Where y = chassis size, M (mini), B (low), C (high)

Where z = number of ports (2, 4, 8, 12, or 16)

Size	M chassis 8.8 x 4.85 x 1.75 in. 22.3 x 12.3 x 4.4 cm. B chassis 16.7 x 4.85 x 1.75 in. 42.4 x 12.3 x 4.4 cm. C chassis 16.7 x 4.85 x 3.50 in 42.4 x 12.3 x 8.9 cm
Weight	2/4 port, M chassis 4lb / 1.8kg. 8 port, B chassis 6lb / 2.7kg. 4/8 port, C chassis 7lb / 3.2 kg 12/16 port, C chassis 8lb / 3.6 kg
Environment	0 – 45° C / 32 – 113° F, 5%-80% non-cond. RH
Power	Auto-switching 100 – 240 VAC - Input - 100-240 VAC 0.45A, 50/60Hz - Output - +5Vdc, 15W. 1.0A Power supply is installed internally and input power is provided through a standard IEC320 male international connector. Power supply is protected by a Type 2AG, 3.5A, 250V fuse.
Connectors	Power – IEC 320 standard receptacle CPU/KVM connector – DB25F RS232 connector – RJ12, 6 conductor
Video bandwidth	250 KHz
Video sync	HV, composite, and sync-on-green
Chassis	Electro galvanized steel, black powder coated
Controls	Power switch, - / + switch
Indicators	1 Power LED 4-16 Select LEDs 4-16 Computer power LEDs
Approvals	FCC Class A/B, UL, cUL, TUV, CE, VCCI-A, CB

## **Appendix D. Rack mount instructions**

---

The UltraView Pro can be mounted in a rack using the Rackmount kits from Rose Electronics.

The optional rack mount kit includes the following items:

- Two black anodized mounting brackets.
- Four 6-32 x 3/8" flat head mounting screws.

To rack mount your UltraView Pro, attach the two rack mounting brackets to your unit with the short flange against the unit using the four screws provided. Secure the mounting brackets to the rack using the appropriate size bolts, nuts and lock washers. Using hardware other than that provided could cause damage to the electronics and/or result in loss of mounting integrity. Do not over tighten the screws used to mount the unit to the mounting brackets.

The following general guidelines should be observed when installing your unit into a rack.

1. The UltraView Pro is designed to work in an ambient temperature of 0° C to 45° C (32° F – 113° F).
2. Units should be placed (1) rack space apart from each other and from other equipment.
3. Rack vent panels (1 space) should be installed between units to provide adequate air flow to the unit.
4. Keep front and rear doors closed on racks equipped with forced air blowers or fans.
5. Do not block power supply vents or otherwise restrict airflow when rack-mounting this unit.
6. Mechanical loading of the rack should be considered to prevent instability and possible tipping over.
7. Tighten all connectors securely and provide adequate strain relief for all cables.
8. Provide a grounded power source to all units. Pay special attention to overall branch circuit load ratings before connecting equipment to this source. Overloaded circuits are potential fire hazards and can cause equipment failures or poor performance.

## Appendix E. Rack mount illustration

---

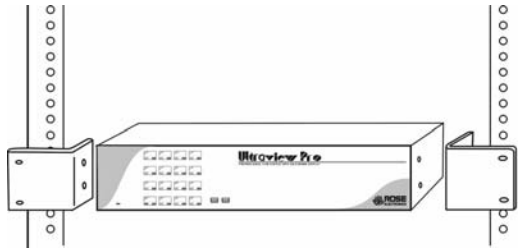

## Appendix F. Keyboard mapping

---

Sun / Apple keyboard emulation (101/102 keyboard)

PC key	Sun function	Apple function
Left alt	Left meta	Left apple / cloverleaf
Right alt/alt graph	Alt graph	Right option
Right control	Power key	Power key

Sun / Apple keyboard emulation (104/105 keyboard)

PC key	Sun function	Apple function
Left window	Left meta	Left apple / cloverleaf
Left alt	Left alt	Left option
Right alt/alt graph	Alt graph	Left option
Right windows	Right meta	Left Apple / cloverleaf
Right windows (app)	Power key	Power key
Right control	Compose	Left control

## Appendix G. Video distance capability

The table below shows the distances, resolution, and quality of video that can be expected with normal or coax cabling. This table applies to the MASTER unit only. There will be some degradation when units are chained together.

Resolution	5'	10'	20'	30'	50'	75'	100'	125'	150'	200'
640x480 60Hz refresh	N4 C4	N4 C4	N4 C4	N4 C4	C4	C4	C4	C4	C3	C3
640x480 72-75Hz refresh	N4 C4	N4 C4	N4 C4	N3 C4	C4	C4	C4	C3	C3	C3
800x600 non-interlaced	N4 C4	N4 C4	N3 C4	N3 C4	C4	C4	C4	C3	C3	C3
1024x768 interlaced	N4 C4	N3 C4	N3 C4	N3 C4	C4	C4	C3	C3	C3	C3
1024x768 non-interlaced	N4 C4	N3 C4	N3 C4	N3 C4	C4	C3	C3	C3	C3	
1280x1024 interlaced	N3 C4	C4	C3	C3	C3	C3				
1280x1024 non-interlaced	N3 C4	C4	C3	C3						

### Legend

N – Normal cabling  
C – Coax cabling

- 4- Perfect or near-perfect video; Unable to easily detect defects.
- 3- Very acceptable; Images clear, small reflections around colored letters
- 2- Acceptable: Slightly fuzzy images, readable text, acceptable usage for short periods of time, can cause eye fatigue.
- 1- Unusable; images smeared, text not easily readable.





**Server Management**



**Solutions**

---

10707 Stancliff Road  
Phone: (281) 933-7673



Houston, Texas 77099  
[WWW.ROSE.COM](http://WWW.ROSE.COM)